

Document 00900

ADDENDUM NO. 2

Date of Addendum: April 29, 2026

PROJECT NAME: City of San Juan – Street Improvements Project

PROJECT NO: 003-2025

BID DATE: May 7, 2026

FROM: LeFevre Engineering, PLLC.  
818 Mansfield Dr. Unit 182  
Port Mansfield, Texas 78598

TO: **Prospective Bidders**

This Addendum forms a part of the Bidding Documents and will be incorporated into Contract Documents, as applicable. Insofar as the original Project Manual and Drawings are inconsistent, this Addendum governs. Acknowledge receipt of the Addendum by inserting its number in Document 00310 - Form of Proposal. **FAILURE TO DO SO MAY SUBJECT BIDDER TO DISQUALIFICATION.**

ADDENDUM NO. 2

Item No. 1 – Section 00100 of the Project Manual has been revised and is attached to this addendum. Please use this form in all required submittals. Litigation History has been added to the Notice to Bidders.

Item No. 2 – Section 00405 of the Project Manual has been revised and is attached to this addendum. Please use this form in all required submittals. Item descriptions have been added to the form of proposal and supersede all quantities in plans and specifications.

Item No. 3 – Section 00420 of the Project Manual has been revised and is attached to this addendum. Please use this form in all required submittals. Litigation History has been added to the Statement of Qualifications.

**SPECIFICATIONS**

[1. Section 02756 – Cold Milling – Please be advised of the following addition to the specification:

3.03 A (d) “The City of San Juan has requested that all salvaged asphaltic millings will remain the property of the City of San Juan and shall be hauled to a specific site as directed by the Engineer and the City of San Juan.”

**PLANS**

1]. Sheet 6.1 of the proposed set of plans has been revised. The detail for Douglas RD. has been revised to 2” of asphalt overlay. Revised Sheet 6.1 is attached to this addendum.



END OF ADDENDUM NO. 2

DATED: 4-29-26

---

Richard LeFevre, P.E.

END OF DOCUMENT

Document 00100

**INSTRUCTIONS TO BIDDERS**

1.00 SUMMARY

1.01 DOCUMENT INCLUDES

- A. Bid Documents and Contract Documents.
- B. Site Assessment.
- C. Subcontractors/Suppliers/Others.
- D. Bid Submission.
- E. Bid Enclosure Requirements.
- F. Determining Lowest Responsive, Responsible Bidder
- G. Offer, Acceptance, Rejection.

1.02 RELATED DOCUMENTS

- A. Document 00020 - Notice to Bidders: Date, time and place for receipt of bids; Contract Time.
- B. Document 00310 - Form of Proposal.
- C. Document 00405 - Schedule of Unit Price Work.
- D. Document 00450 - Post Bid Procedures.
- E. Document 00500 - Agreement.
- F. Document 00700 - General Conditions.
- G. Document 00800 - Supplementary Conditions.

2.00 BID DOCUMENTS AND CONTRACT DOCUMENTS

2.01 DEFINITIONS

- A. Definitions set forth in Document 00700 – General Conditions and in other Contract Documents, are applicable to the Bid Documents.
- B. Addenda: Written or graphic instruments issued prior to the opening of Bids, which clarify, modify, correct, or change the Bid Documents.
- C. Alternate Bid: The total amount bid for alternates to the Work, as described in the Bid Documents. Each Alternate Bid shall include the cost of effects on adjacent or related components, and the Contractor's overhead and profit.
- D. Bid Documents: The Project Manual and Drawings, including Addenda, plus Notice to Bidders, Instructions to Bidders, and Supplements to Bid Forms identified in Document 00310 - Form of Proposal.

## INSTRUCTIONS TO BIDDERS

---

- E. Bidder: A person or entity who submits a Bid.
- F. Lowest Responsible Bidder: The apparent successful Bidder who qualifies as a responsible Bidder and who submits the Bid with the lowest Total Bid Price.
- G. Bid, Offer, Bidding: The act of submitting a complete and properly signed offer in accordance with these Instructions to Bidders. The Bid will be in the English language.
- H. Total Bid Price: The monetary amount for performing the Work as identified by the Bidder in Document 00310 - Form of Proposal, which amount includes Cash Allowances. Bid Price(s) will be in United States Currency.
- I. Security Deposit: A certified check, cashiers check or bid bond in at least the sum of 5 percent of the greatest amount of the Total Bid Price or Total Alternate Bid Price(s), if any.

### 2.02 QUESTIONS, INTERPRETATIONS

- A. Bidder shall: 1) carefully study the Bid Documents and compare them with each other, 2) examine the site, conditions thereon, and local conditions, and 3) report at once to the Engineer any errors, inconsistencies or ambiguities discovered.
- B. Direct questions to Engineer.
- C. Verbal discussions and answers are not binding. Requests from Bidders for clarifications and interpretations of content of documents must be in writing (mail or facsimile transmission only), and must be received not less than 3 business days before the date set for receipt of Bids.
- D. The reply will be by Addendum.

### 2.03 ADDENDA

- A. Addenda issued to Bidding Requirements are applicable only during the bidding period. Addenda to the Post-Bid Procedures are applicable only through the issuance of the Notice to Proceed. Any Addenda issued to Contract Forms, Conditions of the Contract, Specifications or Drawings become a part of the Contract Documents. Include resultant costs in the Total Bid Price.
- B. Addenda will be issued by the Engineer to potential Bidders of Record by mail, Email or facsimile transmission. **Potential Bidders of Record are those that have purchased bid documents.**
- C. Each Bidder shall ascertain, prior to submitting a Bid, that the Bidder has received all Addenda issued. The Bidder shall acknowledge their receipt in the place indicated in Document 00310 - Form of Proposal.

### 2.04 SUBSTITUTIONS OF MATERIALS/EQUIPMENT

- A. No substitutions will be considered on this Project during the bidding period.
- B. Voluntary substitutions by the Bidder will not be considered.

### 3.00 SITE ASSESSMENT

## INSTRUCTIONS TO BIDDERS

- A. Bidders shall examine the Project site before submitting a Bid, become familiar with local conditions under which the Work will be performed, conduct appropriate explorations, and correlate personal observations with requirements of the Bid Documents. Work will be performed in public right-of-way or easements. The site may be examined at any time during daylight hours.
- B. Bidder shall make site investigations to the extent Bidder deems necessary to ascertain the extent of subsurface conditions and variations thereof.
- C. Failure to perform such investigations during the bid period shall not relieve Bidder from responsibility for investigations, interpretations and proper use of available information in preparation of Bidder's proposal.
- D. Publications by the United States Department of Agriculture, Soil Conservation Service and others may be helpful to the bidder in his subsurface site investigation.
- E. Geotechnical investigation reports for the proposed project may also be helpful to the bidder in his subsurface site investigation.

### 4.00 SUBCONTRACTORS/SUPPLIERS/OTHERS

- A. The Owner reserves the right to reject a proposed Subcontractor or Supplier for reasonable cause.

### 5.00 BID SUBMISSION

#### 5.01 SUBMISSION PROCEDURES

- A. Bidders shall be solely responsible for the delivery of their Bids in the manner and time prescribed in Document 00020 - Notice to Bidders.
- B. Submit one copy of the executed offer on the bid forms provided, properly signed, with required Security Deposit, and other Supplements to Bid Forms, in a sealed, opaque envelope. On the outside of the envelope, clearly indicate that it is a sealed bid and include the Bidder's name, Project name and Owner name. Bids submitted by mail shall be enclosed in a separate envelope addressed for mailing, and identifying the enclosure as a bid.
- C. Fill in all blanks in the Bid forms. Acknowledge receipt of Addenda. Bid all Alternate Bids required by Bid Documents.
- D. A summary of submitted Bids will be made available to Bidders two working days following the Bid Opening when requested.
- E. All costs and expenses incurred by the Bidder that are associated with preparation of the Bid shall be paid by and be the sole responsibility of the Bidder.
- F. A list of all Manufacturers, all equipment, and all subcontractors shall be provided in sealed bid proposal. Failure to include the items will be cause for rejection of bid.
- G. A list of all litigation for the past five (5) years with prime contractor and/or all subcontractors to be used on the project including summary of judgement, summary of occurrence, parties involved, year of incident, and current status of the litigation.

#### 5.02 BID INELIGIBILITY

## INSTRUCTIONS TO BIDDERS

- A. Failure to provide required Security Deposit in the proper amount will be cause to declare the Bid invalid.
- B. Improperly completed information may be cause for declaring the Bid invalid.
- C. Bids that are unsigned, improperly signed, illegible, obscure, altered, or which contain qualifications or irregularities of any kind, may be declared invalid. Document 00310 - Form of Proposal, Supplements to the Bid Forms identified in the Form of Proposal, or enclosures which are improperly prepared, may be declared invalid.

### 6.00 BID ENCLOSURE REQUIREMENTS

### 6.01 SUPPLEMENTS TO BID FORMS

- A. Bid submittals shall include any other documents specified in Document 00310 - Form of Proposal.
- B. Proposals must be labeled clearly on the outside of the proposal envelope, listing the CIPP product name and Contractor being proposed. Only proposals using pre-approved products and Contractors will be opened and read. Proposals submitted on products and/or from Contractors that have not been pre-approved will be returned unopened.**

### 6.02 SECURITY DEPOSIT

- A. Bids shall be accompanied by a Security Deposit of 5% of the greatest amount of the Total Bid Price or Total Alternate Bid Price(s), if any.
- B. The Security Deposit of the Bidders will be retained until after the Contract is executed.
- C. After execution of the Contract, Security Deposits will be returned to the Bidders.
- D. If no Contract is awarded, all Security Deposits will be returned to the respective Bidders.

### 6.03 CERTIFIED CHECK/CASHIER'S CHECK

- A. Make certified check or cashier's check (security checks) payable to the Owner.
- B. The security checks are submitted on the condition that if the Bidder is named apparent Low Bidder and then fails either to timely execute the Agreement or to timely provide any required bonds, or to do both, then in that event the Owner will cash the security check.
- C. The Owner will retain an amount equal to the difference between the Bid of the Bidder Providing the security check and the Bid of the Bidder who is finally awarded the Contract and who executes the Agreement and provides the required bonds.
- D. Any balance remaining will be reimbursed by the Owner to the Bidder who provided the security check.

### 6.04 BID BOND

- A. The bid bond must be a valid and enforceable bond, executed by a corporate Surety authorized by the Texas State Board of Insurance to conduct insurance business in the State of Texas and shall comply with other requirements set out by law or included in the Bid Documents.

## INSTRUCTIONS TO BIDDERS

- B. Endorse the bid bond in the name of the Owner as obligee, signed by the Contractor as principal and executed, signed and sealed by the Surety.
- C. The bid bond must be conditioned such that if the Bidder is named apparent Low Bidder or is conditionally awarded the Contract and then fails either to execute the Agreement timely or to provide any required bonds timely, or to do both, then in that event the Surety will be obligated to pay to the Owner an amount equal to the difference between the Bid of the Bidder on whom the bond was written and the Bid of the Bidder who is finally awarded the Contract and who executes the Agreement and provides the required bonds, up to the penal sum of the Bond.
- D. In addition, the Owner expressly reserves the right to reject any Bid if the Bid Bond (or Bid Bond rider) conditions the Bid in a way inconsistent with the Bid Documents. Examples include but are not limited to:
  - 1. a condition prohibiting the Owner from making a Claim against the Performance Bond Surety that would be allowable under the Contract and Performance Bond form published in the Bid Documents;
  - 2. a condition that provides that the Performance Bond Surety cannot be held liable for completing the Contract in case of default; or
  - 3. a condition limiting the Performance Bond Surety's liability for damages inconsistent with the Contract and Performance Bond form published in the Bid Documents.

### 6.05 BID FORM SIGNATURE

- A. Document 00310 - Form of Proposal shall be signed by the Bidder as follows:
  - 1. Sole Proprietorship: Full name, address, and signature of sole proprietor, signed in the presence of a witness who will also sign. Insert the words "Sole Proprietor" under the signature.
  - 2. Partnership: Name and address of the firm, signature of each partner in the presence of a witness who will also sign. The full name and address of each partner shall be given.
  - 3. Corporation: Signature of duly authorized officer.
  - 4. Joint Venture: Each party of the joint venture shall execute Document 00310 - Form of Proposal under their respective seals in a manner appropriate to such party as described above, similar to the requirements of a Partnership.

### 7.00 DETERMINING LOWEST RESPONSIVE, RESPONSIBLE BIDDER

### 7.01 BIDDERS QUALIFICATIONS

- A. Bids must contain evidence of Bidder's qualifications to do business in the State of Texas. To demonstrate that the Bidder is responsible and able to perform the Work, funding policies dictate each Bidder must submit, as a part of the Bidding Documents, all of the items listed below:

00310 Form of Proposal  
00405 Schedule of Unit Price Work  
00411 Bid Bond (Or other Bid Security Deposit as specified herein)

## INSTRUCTIONS TO BIDDERS

00420 Statement of Bidder's Qualifications  
00423 Certification of Bidder's Qualifications  
00425 Equipment & Material Suppliers List (Required)

- B. Only the above data/information provided with the Bidding Documents may be used for evaluation and developing the Recommendation to Award by the Engineer. Bidders will not be allowed to substitute any "Key Personnel" other than alternates presented in the bid or examples of previous projects submitted in the bid package. Clarifications of submitted materials will be permitted after bid opening. Such request for clarifications will only be initiated by the Engineer and only written responses will be accepted.
- C. In determining the lowest responsible, responsive Bidder, in addition to price, the following elements will be considered:
1. The quality, availability, and adaptability of the supplies, materials, equipment, or contractual services, to the particular use required;
  2. The ability, capacity and skill of the bidder to perform the contract or to provide the service required;
  3. Whether the bidder can perform the contract and provide the service promptly, or within the time required, without delay or interference;
  4. The character, responsibility, integrity, reputation, and experience of the bidder;
  5. The quality of performance of previous services, or contracts;
  6. The previous and existing compliance by the bidder with laws relating to the contract or service;
  7. Any previous or existing noncompliance by the bidder with specifications, or requirements relating to time of submission of specified data such as samples, models, drawings, certificates, or other information;
  8. The sufficiency of the financial resources and ability of the bidder to perform the contract or to provide the service; and
  9. The ability of the bidder to provide competent personnel for the job, as demonstrated by the submitted listing of the names and the skills of experienced personnel, including potential alternates, whom the bidder currently employs and who will be available for performing this work;
  10. The experience of the bidder in performing work similar in type, size and complexity to this project, as demonstrated by a listing of projects, with verifiable references (names, addresses, phone numbers, etc.), successfully completed.
  11. Bidder shall provide with the Bid an experience statement with pertinent information regarding similar projects and other evidence of qualifications for each such Subcontractor, Supplier, person, or organization.
  12. The City of San Juan will score based on the following criteria including those listed above:

### 7.02 BIDDER MUST MEET THE FOLLOWING MINIMUM CRITERIA:

- (A) The Bidder must demonstrate \*\*Successful Completion during the last five (5) years of at least three (3) projects comparable in nature and scope to this project. The comparable scope shall be at least 1/2 the size of the proposed project.
- (B) At least two \*Key Personnel, and their potential alternate, employed by the Bidder must have a minimum of eight (8) years experience in similar construction projects.
- (C) The Bidder must have an employee, to be dedicated to this project, who is experienced in scheduling, with demonstrated ability in employing scheduling techniques similar to those to be used for this project.
- (D) Bidder may, at its discretion, include resumes of alternates for Key Personnel, and

## INSTRUCTIONS TO BIDDERS

if in the process of bid evaluation, the Owner rejects any Key Personnel, the Owner will consider the alternates.

\* **KEY PERSONNEL:** Individuals who will be directly assigned to this project. Resumes of Key Personnel must be submitted with the Bid (include in Document 00420) and accepted by the Owner in order for Bidder to receive the Award. At the minimum, the resumes for the following personnel that are to be assigned to this Project are to be submitted.

- (a) Owner or Principals of the Bidder
- (b) The Project Manager
- (c) The Project Superintendent

**\*\*SUCCESSFUL COMPLETION:** Defined as completion of a project on time, no more than thirty (30) days later than the original contract time, and within budget, within 5% of the original contract price. If there is any project submitted by the Bidder as qualifying, but which does not meet these requirements, in order to be fully responsible, the Bidder is required to submit detailed information on that project demonstrating what caused the increases to cost or time. The name and telephone numbers of the Design Engineer and the Client are to be provided for evaluation as to whether the project may be considered "successful". For any project where liquidated damages were assessed, the Bidder will not be considered to have been on time.

### 7.03 BIDDERS ARE REQUIRED TO SUBMIT WITH THEIR BID:

00310 Form of Proposal  
00405 Schedule of Unit Price Work  
00411 Bid Bond  
00420 Statement of Bidder's Qualifications  
00423 Certification of Bidder's Qualifications  
00425 Equipment & Material Suppliers List

- (A) Failure to submit these items with the bid will result in a finding that the bid is non-responsive and the bid will be disqualified.

### 7.04 The Owner will evaluate and compare only the bids determined to be responsive in accordance with the following:

- (a) Is the bid complete (all Bidding Documents submitted);
- (b) Have documents been properly signed;
- (c) Are the required bid securities part of the bid package; and
- (d) Are there any computational errors present?

### 7.05 The Owner reserves the right to accept or reject any variation, deviation, or alternative offer which is not submitted in accordance with the bidding documents. Variations, deviations, alternative offers, and other factors that are in excess of the requirements of the bidding documents or which otherwise result in unsolicited benefits for the Owner, shall not be taken into account in bid evaluation.

### 7.06 In evaluating the bids, the Owner will determine for each bid, the evaluated bid price by adjusting the bid price as follows:

- A. Making any correction for errors;
- B. Excluding provisional sums and the provision, if any, for contingencies in the price schedules;
- C. Making an appropriate adjustment for any other quantifiable acceptable non-material variations, deviations or alternative offers; and

## INSTRUCTIONS TO BIDDERS

---

- D. Making appropriate adjustments to reflect additional factors in the manner and to the extent indicated in the Bidding Documents.
- 7.07 The Owner intends to award the contract to the bidder whose bid has been determined to be substantially responsive to the bidding documents and who has offered the lowest evaluated bid price provided that such bidder has been determined to be qualified to perform the contract satisfactorily in accordance with the provisions of the Bidding Documents.
- 8.00 OFFER ACCEPTANCE, REJECTION
- 8.01 ACCEPTANCE
- A. The Owner reserves the right to accept any Bid deemed advantageous to it.
  - B. The Owner will give notice of intent to award the Contract to the Low Bidder. Acceptance by the Owner is conditioned upon Bidder's execution of submittals required in Document 00450 - Post-Bid Procedures.
  - C. The Bid shall remain open to acceptance and shall be irrevocable for the Period for Bid Acceptance stated in Document 00020 – Notice to Bidders.
  - D. Additional time taken by Contractor to fulfill requirements for submittals, including review and re-submittal, shall be added to the acceptance period.
- 8.02 REJECTION
- A. The Owner reserves the right to reject any and all Bids.
- 8.03 BID TABULATION
- A. The Engineer will tabulate, record, and evaluate the Bids of all responsible Bidders after the Bid opening.
  - B. In tabulating Bids, the amount written for a unit price governs over the total amount calculated. Therefore, the Engineer may correct any mathematical errors in the extension of the total amount based on the unit price given by a Bidder and adjust their Total Bid Price.

END OF DOCUMENT

Document 00405

SCHEDULE OF UNIT PRICE WORK

This Document, constitutes a Supplement to Document 00310 - Form of Proposal.  
When a Contract is awarded, this Document becomes a supplement to Document 00500 - Form of Agreement between Owner and Contractor.

ITEM NO.	DESCRIPTION	EST. QNTY.	UNIT	UNIT PRICE	TOTAL PRICE
Street Improvements Project - Nebraska Ave & Douglas Street					
<b>General Project</b>					
1-1	Mobilization; bonding, not to exceed 3% of total project	LS	1		
1-2	Installation and maintenance of barricades, signs and traffic handling as per contractor Traffic Control Plan.	LS	1		
1-3	Erosion Control for inlets and Project; complete in place as per plans and specification	LS	1		
<b>Total General Project</b>					
<b>Nebraska Ave - Reconstruction</b>					
2-1	Place 3-inch Hot Mix Asphalt Concrete Type "D" (3-inch compacted thickness) to a width according to the plans and specifications; complete in place.	SY	17075		
2-2	Prime Coat (MC-30) (0.2 GAL/SY), according to the plans and specifications; complete in place.	GAL	3415		
2-3	7-inch Scarify Existing Caliche Base, Subgrade (where needed) and Cold Mill Asphalt; remove material and rework with removed millings and removed flex-base to a mix ratio of 2:1 as per geotech report, (4-inch to 5-inch compacted thickness) to a width according to the plans and specifications complete in	SY	17086		
2-4	Pavement Markings - REFL PAV MARKINGS TYPE 1 - CROSSWALK, TURNING LANE, STOP, CROSSWALK, SHOULDER AND DOUBLE NON-TURNING LANE; and others needed as per plans and specifications; complete in	LS	1		
2-5	Sewer Mahole Adjustments with approved concrete collars; replace 5x5' concrete apron with No. 4 rebar; as per plans and	EA	7		
2-6	Stormwater Grate Inlets Adjustments; complete in place	LS	1		
2-7	Water Valve Adjustments; as per plans and specifications complete in place.	EA	2		
<b>Total Nebraska Ave</b>					

<b>Douglas Street - Overlay</b>					
3-1	Place 2-inch Hot Mix Asphalt Concrete Type "D" (2-inch compacted thickness) to a width according to the plans and specifications; placement of sealant prior to application of asphalt, complete in place.	SY	1445		
3-2	Prime Coat (MC-30) (0.2 GAL/SY), according to the plans and specifications; complete in place.	GAL	289		
3-3	1-inch Scarify Existing Cold Mill Asphalt; replace with new asphalt to a width according to the plans and specifications complete in place.	SY	1440		
3-4	Stormwater Grate Inlets Adjustments; complete in place	EA	2		
3-5	Stripping and pavement markings as per plans and specifications; complete in place.	LS	1		
<b>Douglas Street Overlay Total</b>					

**BASE BID PRICE (Total Unit Prices Plus Cash Allowance, if any)**

\$ \_\_\_\_\_

Notes:

(1) United States Dollars. In the event of a discrepancy, this column shall govern.

Project: \_\_\_\_\_

Project No. \_\_\_\_\_ Bidder's Signature: \_\_\_\_\_

Company: \_\_\_\_\_ Name: \_\_\_\_\_

Date: \_\_\_\_\_ Title: \_\_\_\_\_

END OF DOCUMENT

**STATEMENT OF BIDDER'S QUALIFICATIONS**

DOCUMENT 00420

STATEMENT OF BIDDER'S QUALIFICATIONS

**BIDDER:**

**PROJECT NAME:**

	<b>City of San Juan – Street Improvements Project – Nebraska Ave &amp; Douglas Street</b>
--	---

**1. ORGANIZATION**

1.1 How many years has your organization been in business as a Contractor? \_\_\_\_\_

1.2 How many years has your organization been in business under its present business name?  
\_\_\_\_\_

1.2.1 Under what other or former names has your organization operated?  
\_\_\_\_\_

1.3 If your organization is a corporation, answer the following:

1.3.1 Date of incorporation: \_\_\_\_\_

1.3.2 State of incorporation: \_\_\_\_\_

1.3.3 President's name: \_\_\_\_\_

1.3.4 Vice-president's name(s): \_\_\_\_\_  
\_\_\_\_\_

1.3.5 Secretary's name: \_\_\_\_\_

1.3.6 Treasurer's name: \_\_\_\_\_

1.4 If your organization is a partnership, answer the following:

1.4.1 Date of organization: \_\_\_\_\_

1.4.2 Type of partnership  
(if applicable): \_\_\_\_\_

1.4.3 Name(s) of general  
partner(s): \_\_\_\_\_

1.5 If your organization is individually owned, answer the following:

1.5.1 Date of organization: \_\_\_\_\_

1.5.2 Name of owner: \_\_\_\_\_

**STATEMENT OF BIDDER'S QUALIFICATIONS**

---

1.6 If the form of your organization is other than those listed above, describe it and name the principals:

---

---

**2. LICENSING**

2.1 List jurisdictions and trade categories in which your organization is legally qualified to do business, and indicate registration or license numbers, if applicable. Indicate name, license number and expiration date for Master Plumber or other trade required under the Instructions to Bidders section of this Bid.

---

---

2.2 List jurisdictions in which your organization's partnership or trade name is filed.

---

---

**3. EXPERIENCE**

3.1 List the categories of work that your organization normally performs with its own forces.

---

---

3.2 Claims and Suits. (If the answer to any of the questions below is yes, please attach details.)

3.2.1 Has your organization ever failed to complete any work awarded to it? \_\_\_\_\_

3.2.2 Are there any judgments, claims, arbitration proceedings or suits pending or outstanding against your organization or its officers? \_\_\_\_\_

3.2.3 Has your organization filed any law suits or requested arbitration with regard to construction contracts within the last five years? \_\_\_\_\_

3.3 Within the last five years, has any officer or principal of your organization ever been an officer or principal of another organization when it failed to complete a construction contract? (If the answer is yes, please attach details.) \_\_\_\_\_

3.4 On a separate sheet, list major construction projects your organization has in progress, giving the name of project, owner, architect, contract amount, percent complete and scheduled completion date. Required to have three (3) in the last eight (8) years.

3.4.1 State total worth of work in progress and under contract: \_\_\_\_\_

**STATEMENT OF BIDDER'S QUALIFICATIONS**

3.5 On a separate sheet, list **ALL** the major projects your organization has completed in the past five years, giving the name of project, owner, architect, contract amount, date of completion and percentage of the cost of the work performed with your own forces. Failure to provide **ALL** projects constructed may result in rejection of bid.

3.5.1 State annual amount of construction work performed each year during the past five years:

Year	Contract Amount	Final Amt. Including Change Orders
_____	_____	_____
_____	_____	_____
_____	_____	_____
_____	_____	_____
_____	_____	_____

3.6 On a separate sheet, list the construction experience and present commitments of the key individuals of your organization. Submit resumes of Key Personnel (as defined in the Instructions to Bidders. Bidder hereby certifies that the Resident Superintendent has the authority to act on behalf of the Contractor at all times. No substitution shall be made without the written authorization of the Owner and the Engineer based upon acceptance of the qualifications of the proposed substitute.

3.7 **Provide form 00423 "Certification of Bidder's Qualifications" as evidence that the Bidder meets the minimum criteria called out in the Instructions to Bidders.**

**4. REFERENCES**

4.1 On a separate sheet, list three (3) Trade References and two (2) Bank References :

4.2 Surety:

Name and telephone number of Bonding Company: \_\_\_\_\_

\_\_\_\_\_

Name, telephone and address of Agent:

\_\_\_\_\_

\_\_\_\_\_

\_\_\_\_\_

\_\_\_\_\_

**STATEMENT OF BIDDER'S QUALIFICATIONS**

**5. Litigation History**

5.1 Please provide Litigation History for the past five (5) years for the Prime Contractor and all subcontractors to be utilized for this project. You may use a separate sheet of paper(s) if necessary and attach to this document.

Year	Parties	Summary of Litigation	Status

**6. SIGNATURE**

6.1 To be executed by a Principal of the firm authorized to certify the foregoing information:

\_\_\_\_\_, being duly sworn, deposes and says that the information provided herein is true and sufficiently complete so as not to be misleading.

6.2 Dated at \_\_\_\_\_ this \_\_\_\_ day of \_\_\_\_\_, 2026.

Name of Organization: \_\_\_\_\_

By: \_\_\_\_\_

Printed Name: \_\_\_\_\_

Title: \_\_\_\_\_

END OF DOCUMENT

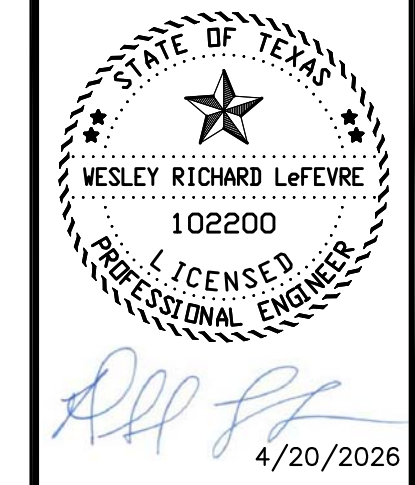

CITY OF SAN JUAN  
SAN JUAN, TEXAS 75589

OWNER:  
**DETAIL SHEET**

DRAWN BY: CADD  
CHECKED BY: W.R.L.  
APPROVED BY: W.R.L.  
DATE: 04/20/26  
REVISED DATE: -  
SCALE 11 X 17: -  
SCALE 24 X 36: -  
PROJECT #: 005-2023  
FILE NAME: SHEET

C-6.1

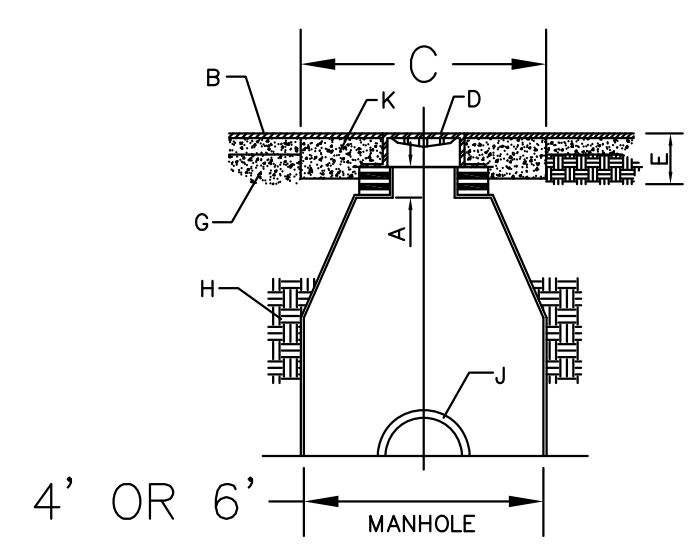
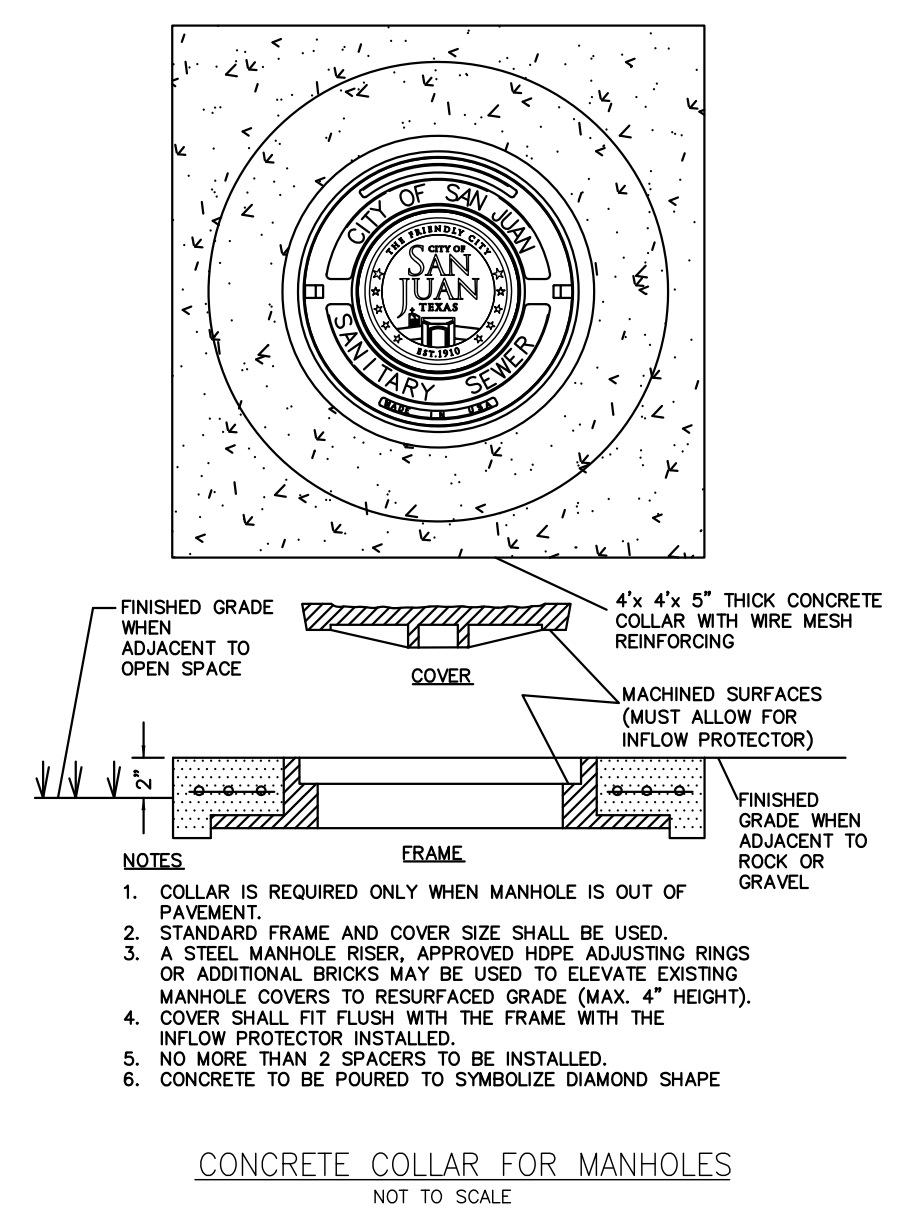
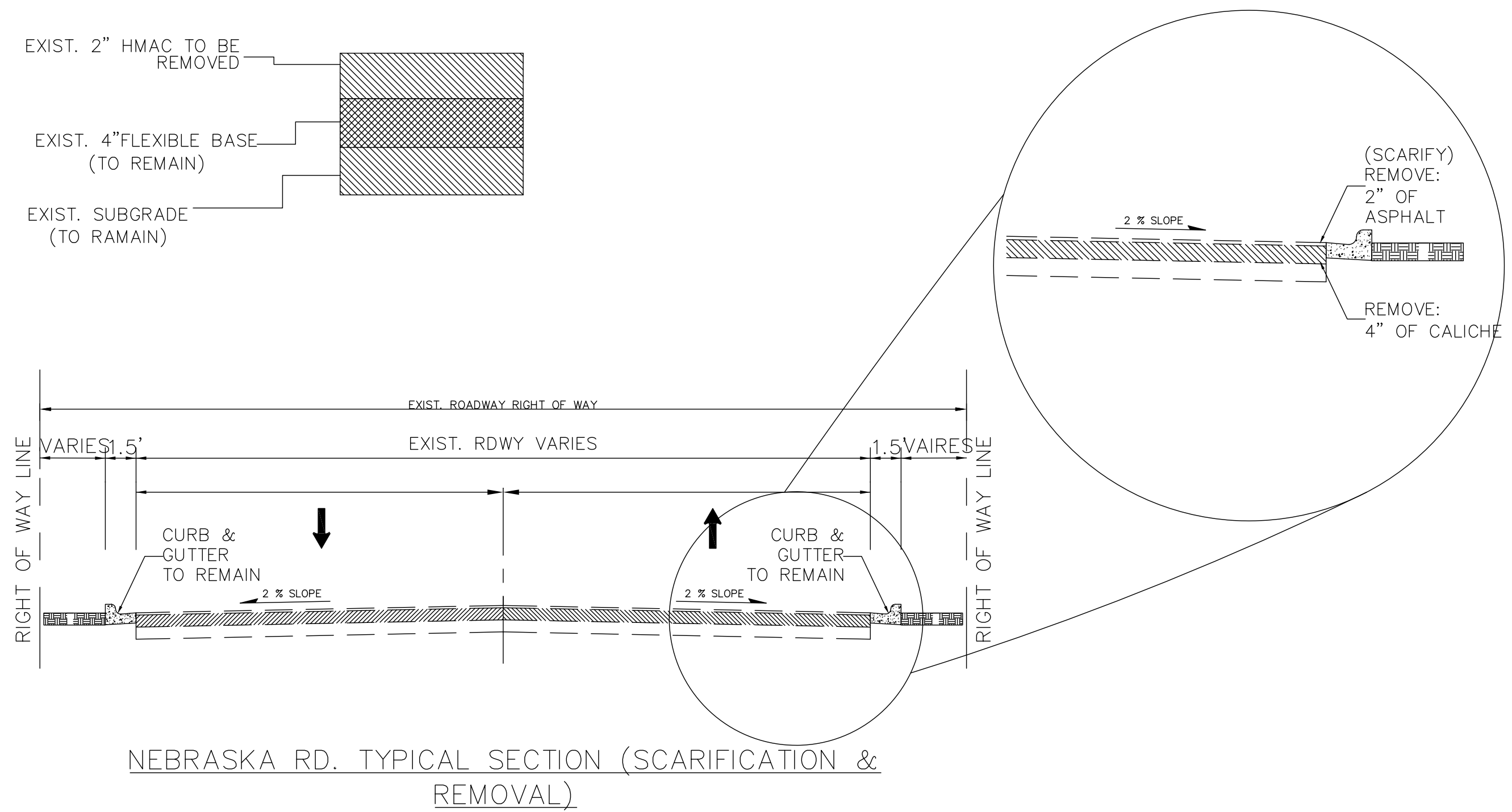

- GENERAL NOTES:
- ADJUSTMENT TO GRADE OF FRAME AND COVER SHALL BE MADE BY VARYING NUMBER OF HDPE GRADE RINGS DIRECTLY UNDER FRAME USING A MINIMUM OF ONE RING UP TO A MAXIMUM OF 12 INCHES TOTAL. IF ADJUSTMENT REQUIRES MORE THAN 12 INCHES, THE CONE SHALL BE REMOVED, BARREL HEIGHT ADJUSTED AND CONE REPLACED.
  - FOR SHALLOW ADJUSTMENTS, WATER VALVE EXTENSION COLLAR & INSERT MAY BE USED.
  - ALL SEATING SURFACES BETWEEN INDIVIDUAL GRADE RINGS, FRAME, AND MANHOLE BRICK LEDGE SHALL BE SEALED USING 1/2" BUTYL SEALANT.
- CONSTRUCTION NOTES:
- A. HDPE GRADE RINGS, ONE RING MINIMUM, 12" MAX. TOTAL
  - B. OVERLAY
  - C. USE A REINFORCED CONCRETE PAD 5' X 5' X 8" IN ALL PAVED AREAS
  - D. MANHOLE FRAME & COVER
  - E. STANDARD PAVING SECTION
  - F. FLEX BASE
  - G. SUBGRADE
  - H. SUBGRADE
  - J. SEWER LINE
  - K. NEW PORTLAND CEMENT CONCRETE.
  - L. NEW PAVING MATERIAL
  - M. EXISTING PAVEMENT
  - N. CUT LINE
  - P. EXISTING CONCRETE
  - Q. VALVE BOX EXTENSION

MANHOLE ADJUSTMENT DETAIL  
SCALE: N.T.S.

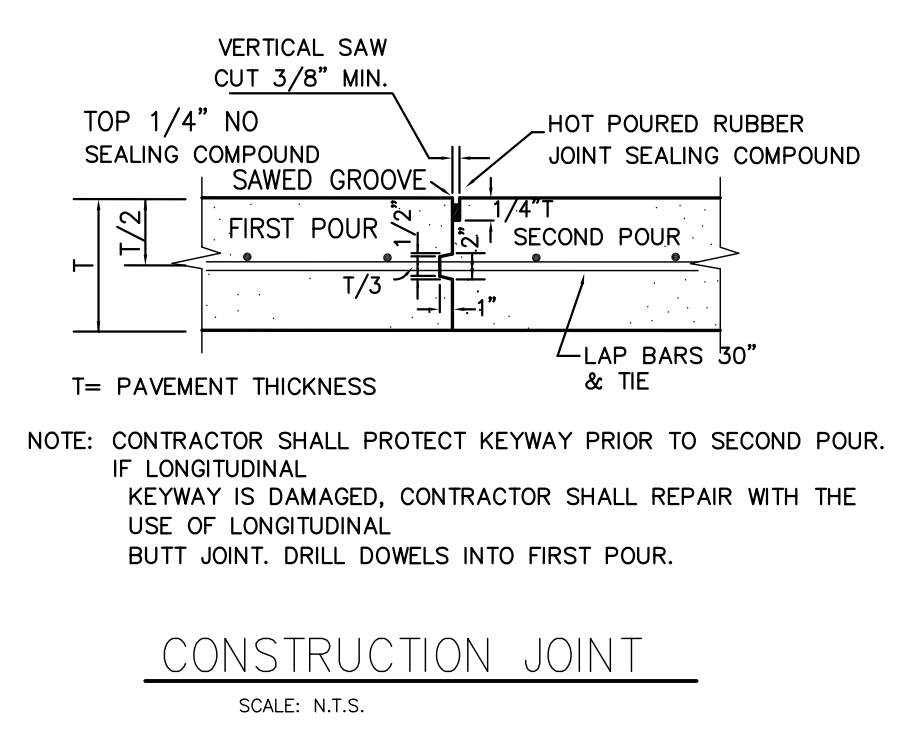
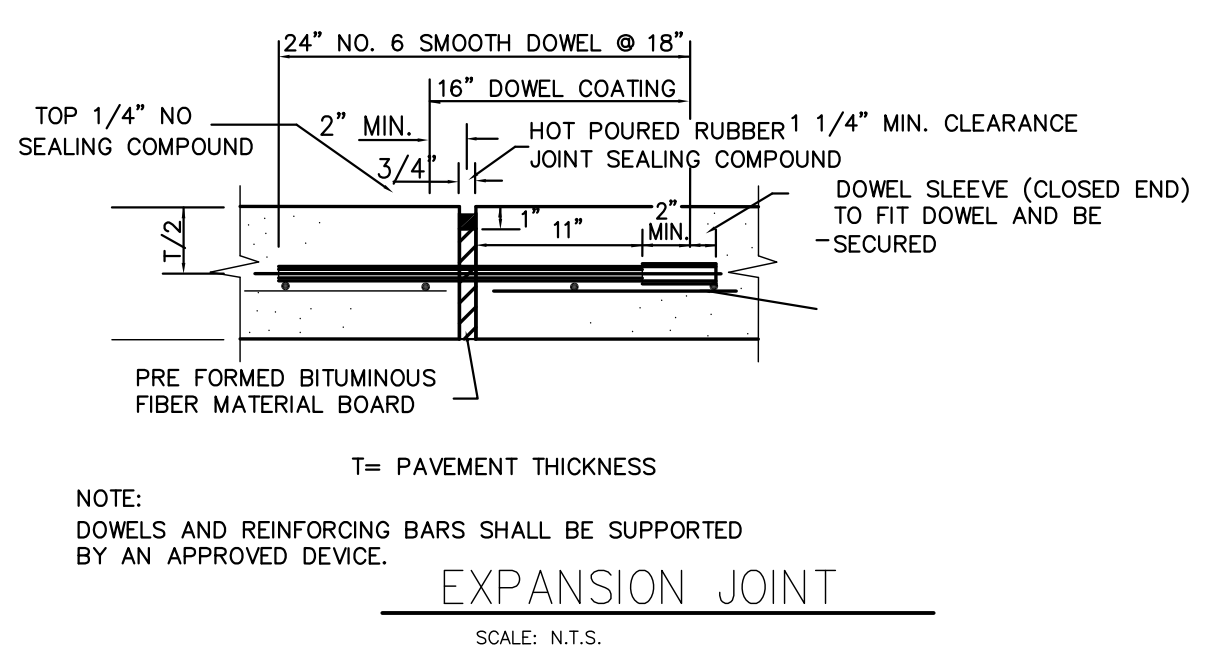
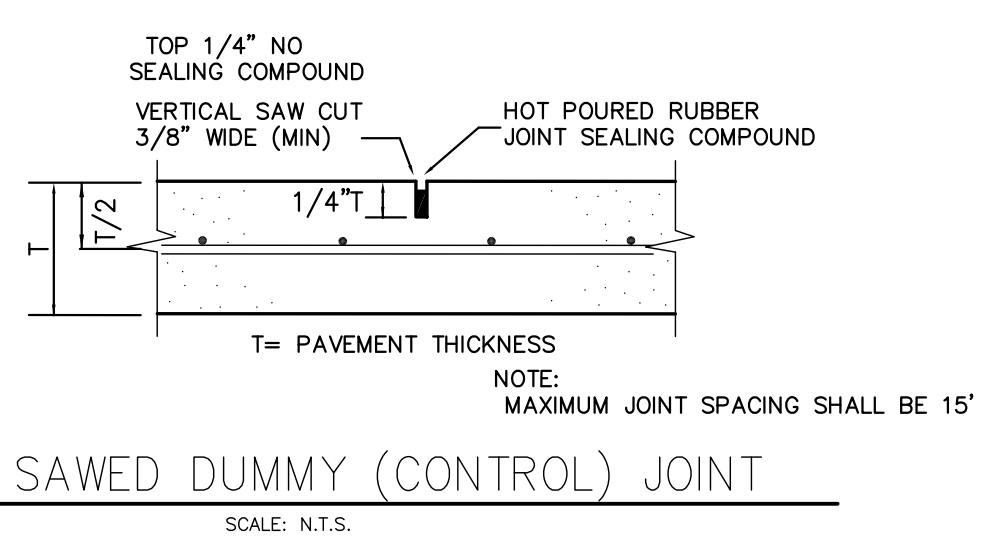
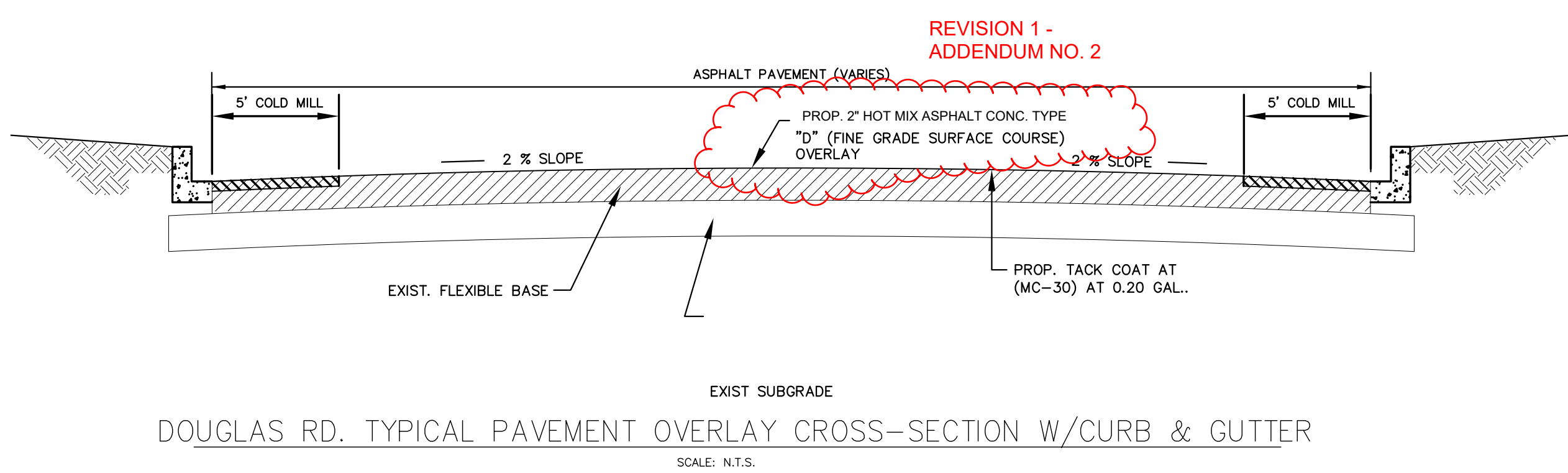

REVISIONS		
NO.	DATE	COMMENTS
1	4-29-26	REVISION OF DOUGLAS RD. DETAIL